

## **CEN Standard 12566-3: 2005**

### **Small wastewater treatment systems for up to 50 PT — Part 3: Packaged and/or site assembled domestic wastewater treatment plants**

*Kleinkläranlagen für bis zu 50 EW — Teil 3: Vorgefertigte und/oder vor Ort montierte Anlagen zur Behandlung von häuslichem Schmutzwasser*

*Petites installations de traitement des eaux usées jusqu'à 50 PTE — Partie 3 : Stations d'épuration d'eaux usées domestiques fabriquées en usine et/ou assemblés sur site*

**Harmonised as a European Standard 1.5.2006  
Reference Official Journal of the European Union 2005 / C 319/01 dated 14.12.2005  
Working document number: prEN 12566-3: 2001**

## Contents

1	Scope .....	4
2	Normative references .....	5
3	Terms and definitions .....	6
4	Nominal Designation .....	6
5	Specifications.....	7
5.1	Dimensions.....	7
5.1.1	Inlets, outlets, internal pipework and connections .....	7
5.1.2	Access .....	7
5.1.3	Sizing basis .....	7
5.2	Construction.....	7
5.3	Treatment efficiency.....	8
5.4	Watertightness.....	8
5.5	Structural requirements .....	8
5.5.1	General.....	8
5.5.2	Backfill load.....	9
5.5.3	Hydrostatic loads.....	9
5.5.4	Dynamic loads.....	9
5.5.5	Crushing resistance/maximum load deformation .....	10
5.6	Durability .....	10
6	Test methods.....	10
6.1	Treatment efficiency testing procedure .....	10
6.2	Calculation and test methods for structural behaviour.....	10
6.3	Watertightness.....	10
7	Marking .....	10
8	Quality control.....	10
8.1	Evaluation of conformity.....	11
8.1.1	General.....	11
8.1.2	Initial type tests.....	11
8.2	Factory production control.....	11
8.2.1	Raw materials and components.....	12
8.2.2	Production process .....	12
8.2.3	Finished product testing.....	12
8.2.4	Stock control .....	12
9	Installation instructions .....	12
10	Operation and maintenance instructions.....	12
<b>Annex A (normative) Watertightness test.....</b>		<b>14</b>
A.1	<b>Water test.....</b>	<b>14</b>
A.1.1	Sample .....	14
A.1.2	Procedure .....	14
A.1.3	Expression of results .....	14
A.2	<b>Air permeability vacuum test.....</b>	<b>15</b>
A.2.1	Sample .....	15
A.2.2	Procedure .....	15
A.2.3	Expression of results .....	15
A.3	<b>Pneumatic pressure test.....</b>	<b>15</b>
A.3.1	Sample .....	15
A.3.2	Procedure .....	15
A.3.3	Expression of results .....	16

<b>Annex B (normative) Treatment efficiency test procedure</b> .....	17
<b>B.1 Testing Location</b> .....	17
<b>B.2 Plant selection and preliminary evaluation</b> .....	17
<b>B.2.1 General</b> .....	17
<b>B.2.2 Installation and commissioning</b> .....	17
<b>B.2.3 Operation and maintenance procedures during testing</b> .....	17
<b>B.2.4 Data to be monitored</b> .....	17
<b>B.3 Test Procedure</b> .....	18
<b>B.3.1 Time for establishment</b> .....	18
<b>B.3.2 Influent characteristics</b> .....	18
<b>B.3.3 Daily flow pattern for testing</b> .....	19
<b>B.3.4 Timetable for test procedure</b> .....	19
<b>B.3.5 Plant loading</b> .....	20
<b>B.3.6 Stress tests</b> .....	20
<b>B.3.7 Sampling</b> .....	21
<b>B.4 Sample analysis</b> .....	22
<b>B.5 Test report</b> .....	22
<b>B.6 Design changes</b> .....	23
<b>Annex C (normative) Calculation and test methods for structural behaviour</b> .....	24
<b>C.1 General</b> .....	24
<b>C.2 Concrete plant</b> .....	24
<b>C.2.1 Crushing test methods</b> .....	24
<b>C.2.2 Test procedures</b> .....	25
<b>C.3 Polyethylene plant</b> .....	27
<b>C.3.1 Vertical load test</b> .....	27
<b>C.4 Determination of mechanical characteristics of test samples used for calculation</b> .....	28
<b>C.4.1 Concrete</b> .....	28
<b>C.4.2 Glass Reinforced Plastic</b> .....	28
<b>C.5 Vacuum test for Glass Reinforced Plastic or steel plant</b> .....	28
<b>C.6 Pit test</b> .....	29
<b>C.6.1 Sample</b> .....	29
<b>C.6.2 Procedure</b> .....	29
<b>C.6.3 Expression of results</b> .....	30
<b>Annex ZA (informative) Clauses of this European Standard addressing essential requirements or other provisions of EU Directives</b> .....	31

## Foreword

This document has been prepared by CEN /TC 165, "Wastewater engineering".

This document is currently submitted to the CEN formal vote.

This document has been prepared under a mandate given to CEN by the European Commission and the European Free Trade Association, and supports essential requirements of EU Directive(s).

For relationship with EU Directive(s), see informative annex ZA, which is an integral part of this document.

This European Standard provides the general requirements for packaged and/or site assembled treatment plants used for domestic wastewater treatment up to 50 PT (see clause 1 "Scope").

The Standard series EN 12566 "Small wastewater treatment systems up to 50 PT" contains the following parts:

- Part 1 : Prefabricated septic tanks

NOTE 1 This part specifies the requirements and test methods for prefabricated septic tank units.

- Part 3 : Packaged and/or site assembled domestic wastewater treatment plants:

NOTE 2 This part specifies the requirements and test methods used to evaluate packaged wastewater treatment plants which are required to treat sewage to a predetermined standard.

The following parts are in preparation :

- Part 2 : Soil infiltration systems

NOTE 3 Code of Practice for in-situ constructed soil infiltration systems. No treatment requirements are specified.

- Part 4 : Septic tanks built in situ from prefabricated kits – Execution standard

- Part 5 : Filtration systems (including sand filters)

- Part 6 : Test procedure for user site

## 1 Scope

This European Standard specifies requirements, test methods, the marking and factory production control for packaged and/or site assembled domestic wastewater treatment plants (including guest houses and businesses) used for populations up to 50 inhabitants. Small wastewater treatment plants according to this Standard are used for the treatment of raw domestic wastewater.

This part covers plants with tanks made of concrete, Glass Reinforced Plastic (GRP), Polyéthylène (PE), steel.

The test methods specified in this standard establish the performance of the plant, needed to verify its suitability for the end use.

This standard applies to plants which are considered as a treatment plant if all prefabricated components are factory or site-assembled by one manufacturer and which are tested as a whole.

## 2 Normative references

This European Standard incorporates by dated or undated reference, provisions from other publications. These normative references are cited at the appropriate places in the text and the publications are listed hereafter. For dated references, subsequent amendments to or revisions of any of these publications apply to this European Standard only when incorporated in it by amendment or revision. For undated references the latest edition of the publication referred to applies (including amendments).

EN 476, *General requirements for components used in discharge pipes, drains and sewers for gravity systems.*

EN 1085, *Wastewater treatment - Vocabulary*

EN 1189, *Water quality - Determination of phosphorus - Ammonium molybdate spectrometric method*

prEN 12255-1, *Wastewater treatment plants - Part 1: General construction principles.*

prEN 12255-4, *Wastewater treatment plants - Part 4: Primary settlement.*

prEN 12255-6, *Wastewater treatment plants - Part 6: Activated sludge processes.*

prEN 12255-7, *Wastewater treatment plants - Part 7: Biological fixed-film reactors.*

EN 12255-11, *Wastewater treatment plants - Part 11: General data required.*

ENV 12260, *Water quality - Determination of nitrogen - Determination of bound nitrogen, after combustion and oxidation to nitrogen dioxide, using chemiluminescence detection*

EN ISO 11732, *Water quality - Determination of ammonium nitrogen by flow analysis (CFA and FIA) and spectrometric detection.*

EN ISO 11905-1, *Water quality - Determination of nitrogen - Part 1: Method using oxidative digestion with peroxodisulfate*

ISO 5815, *Water quality — Determination of biochemical oxygen demand after 5 days (BOD<sub>5</sub>) — Dilution and seeding method.*

ISO 6060, *Water quality — Determination of the chemical oxygen demand.*

ISO 5664, *Water quality — Determination of ammonium — Distillation and titration method.*

ISO 6778, *Water quality — Determination of ammonium — Potentiometric method.*

ISO 7150-1, *Water quality — Determination of ammonium — Part 1: Manual spectrometric method.*

ISO 7150-2, *Water quality — Determination of ammonium — Part 2: Automated spectrometric method.*

ISO 7890-3, *Water quality — Determination of nitrate — Part 3: Spectrometric method using sulfosalicylic acid.*

ISO 2736

ISO 1920

ISO 4012

EN 63

### 3 Terms and definitions

**For the purposes of this European Standard, the terms and definitions given in EN 1085 and the following apply 3.1 end use**

the condition in which a plant is normally installed and used. There are 2 conditions of use:

- a) in the ground,
  - 1) Inside the building
  - 2) Outside the building
- b) on the top of the ground
  - 1) Inside the building
  - 2) Outside the building

#### **3.2 laboratory**

a body capable of testing a domestic wastewater treatment plant under controlled conditions

#### **3.3 packaged domestic wastewater treatment plant**

prefabricated factory-built waste-water treatment installation which accepts domestic wastewater and treats it to a pre-determined quality.

#### **3.4 range**

For the purpose of evaluation (e.g. for CE marking), products may be grouped into ranges where the selected property(s) is/are similar for all products within each range.

The manufacturer takes into account at least similar shape, equipment, materials and conditions of end use and ensures the minimum treatment efficiency and minimum structural behaviour for all the products in the range.

The minimum level of performance (treatment efficiency and structural behaviour) are given by the test carried on one model of the range.

#### **3.5 site assembled domestic wastewater treatment plant**

a unit composed of prefabricated components assembled on one site by one manufacturer which accepts domestic wastewater and treats it to a pre-determined quality

### 4 Nominal Designation

The manufacturer shall state the nominal organic daily load expressed in kg of BOD<sub>5</sub> or BOD<sub>7</sub> per day and the nominal hydraulic daily flow expressed in cubic metres per day.

## 5 Specifications

### 5.1 Design

#### 5.1.1 Inlets, outlets, internal pipework and connections

The minimum nominal diameter of inlet and outlet pipes for gravity flow are specified below.

- 100 mm ND for flows  $\leq 4\text{m}^3/\text{day}$
- 150 mm ND for flows  $> 4\text{m}^3/\text{day}$

The hydraulic design of the equipment, the internal pipework and connections shall ensure that no backflows, blockage or surcharging occur during normal operation.

#### 5.1.2 Access

Plants shall be designed to prevent unauthorised access and ensure operational safety.

The design shall provide access to the inlet and outlet areas; these access may allow routine maintenance sampling, removal of sludge, cleaning and maintenance.

Extension shafts and access covers shall be fit for purpose. For less than  $6\text{ m}^3$ , they shall have a minimum dimension of 400 mm for square sections or a nominal diameter of 400 for circular sections. A minimum of 600 mm is required for septic tanks with a volume greater or equal than  $6\text{ m}^3$ .

Provisions for man entry shall meet the requirements of EN 476.

**Note** : The requirements to provide facility for man entry may depend on the situation of end use.

#### 5.1.3 Sizing basis

Depending on the end use, one or more of the following design criteria shall be stated:

Rules and units (per inhabitant, BOD, SS,...) to be used for the determination of the population pollution load are given by national regulations

- a) total Population loading;
- b) the minimum and the maximum daily loading that a plant can accept;
- c) minimum volume criteria including sludge storage capacity;
- d) additional design criteria for domestic wastewater flows from sources such as hotels, restaurants or commercial premises. These additional design criteria are chosen according to the national codes of practice or/and regulations

The manufacturer shall state the sludge storage volume expressed in cubic meters and the recommended desludging frequency. Special consideration shall be given to the peak flows received by small plants (see prEN 12255 part 1, 4, 6, 7, 10, 11).

### 5.2 Construction

Plants shall be structurally stable, durable, watertight and corrosion resistant.

Plants shall be provided with an alarm to indicate operational failure (for example electrical, mechanical, hydraulic failure). The manufacturer shall indicate which kind of failure is detected with the alarm.

### **5.3 Treatment efficiency**

The plant shall demonstrate compliance with the wastewater treatment efficiency performances and the related operational data declared by the manufacturer, when tested according to Annex B.

### **5.4 Watertightness**

The plant shall be watertight according to, at least one of the test methods described in Annex A (normative).

The water loss for plants shall be measured after 30 mn. For tanks made of concrete it shall be  $\leq 0,1 \text{ l/m}^2$  of the internal wet surface of the external walls. For tanks constructed of plastics or other material, no leakage shall occur.

### **5.5 Structural requirements**

#### **5.5.1 General**

The plants shall resist the loads and stresses resulting from handling, installation and use including desludging and maintenance, for their design life. Depending on the end use, safety factors (given by National regulations or code of practice) shall be used to calculate the loadings for which the plants are designed.

Depending on the end use, the following loads for the complete equipped plant shall be considered:

- a) backfill load;
- b) hydrostatic loads;
- c) dynamic loads;

For the determination of loads, the following parameters shall be used:

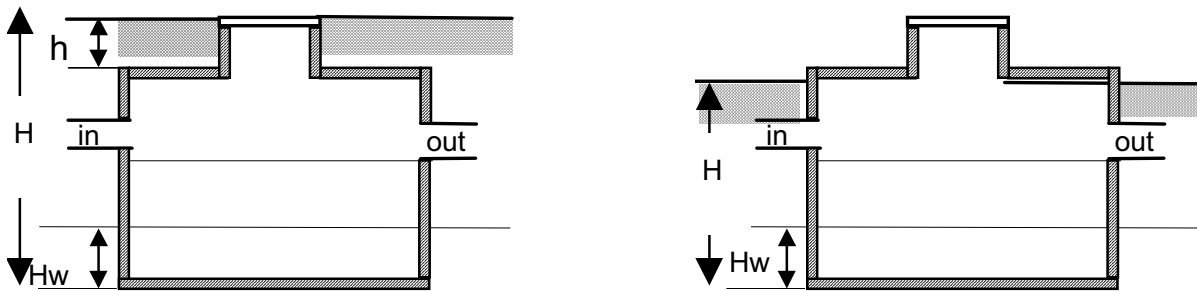

Key

$H_w$  height of exterior water level (groundwater);

$K$  coefficient of horizontal soil pressure;

$h$  depth of the backfill from the top of the tank to ground level.

**Figure 1 —Definition of parameters**

### 5.5.2 Backfill load

Calculation of backfill loads shall take account of the effect of ground conditions, backfill materials and tank shape factors.

vertical component:  $h \times 18$  (kN/m<sup>2</sup>), where 18 kN/m<sup>3</sup> is the specific weight of the soil,

horizontal component:  $K \times D \times 18$  (kN/m<sup>2</sup>), where  $D$  is the distance from the ground level to the point where the load applies.

— For sand:  $K = 0,33$  ;

— For gravel:  $K = 0,27$

— For other backfill materials:  $K = 0,5$

### 5.5.3 Hydrostatic loads

— Vertical component:  $H_w \times 10$  (kN/m<sup>2</sup>).

10 kN/m<sup>3</sup>: action resulting from the specific weight of water.

— Max. horizontal component:  $D \times 10$  (kN/m<sup>2</sup>).

On sites where the groundwater table is significant (groundwater table highest level is above the bottom of the tank), the stability conditions of the product in relation to the water pressure shall be indicated in the manufacturer's instructions. In this case, the specific load of soil is 10 kN/m<sup>3</sup> and shall be added to the water load.

### 5.5.4 Dynamic loads

a) Pedestrian loading:

## prEN 12566-3:2001 (E)

A value of 2,5 kN/m<sup>2</sup> shall be considered only when the height of the backfill is less than 1,00 m. Over 1,00 m pedestrian loading is assumed to be negligible against other actions.

### b) Vehicle loading

Plants subject to vehicle loadings shall be individually designed in accordance with the provisions valid in the place of use.

### 5.5.5 Crushing resistance/maximum load deformation

The structural behaviour of the plant shall be determined by the crushing resistance/maximum load deformation.

## 5.6 Durability

Plants including all internal components, shall be constructed from materials that make them suitable for use in a wastewater environment.

## 6 Calculation and Test methods

### 6.1 Watertightness

Plants shall comply with at least one of the tests described in Annex A.

### 6.2 Treatment efficiency testing procedure

The treatment efficiency of a plant shall be tested in accordance with the method described in Annex B

Alternatively, the test described in prEN12566-6 can be used.

### 6.3 Calculation and test methods for structural behaviour

Plants shall be subjected to a calculation or a test described in Annex C.

## 7 Marking

Plants shall be marked with the following information:

- a) manufacturer and product identification;
- b) The number of this EN12566-3;
- c) nominal organic daily load; (BOD<sub>5</sub> or BOD<sub>7</sub> at kg per day);
- d) nominal hydraulic daily flow; (m<sup>3</sup>/day);
- e) conditions of use;
- f) date of manufacture;
- g) name of laboratory; (where appropriate)
- h) test report number (where appropriate)

Where ZA.3 requires the same information as this Clause 7, the requirements of this clause are met.

## 8 Evaluation of conformity

### 8.1 General

The conformity of the products with the requirements of this Standard shall be demonstrated by:

- a) initial type tests (see 8.1.2.)
- b) factory production control (see 8.2)
- c) finished product test (see 8.2.3)

NOTE For CE marking and relevant product information, AnnexZA. applies.

### 8.2 Initial type tests

Initial type tests shall be performed to demonstrate conformity with this Standard. Tests previously performed in accordance with provision of this standard (same product, same characteristics, test methods, sampling procedure of the system of attestation of conformity) may be taken into account.

In addition when a new product (outside an existing range) or product range is developed, appropriate initial type tests shall be carried out in accordance with the table 1 to confirm that its final properties conform to the requirements of this Standard.

If a modification, likely to alter the functional properties of the finished product, takes place, the initial type tests shall be repeated.

The results of the initial type tests shall be recorded and available for inspection.

**Table 1 — Requirements for initial type tests**

Requirements	Models to be tested	
	Each model in a range	A representative model from a range
1. • Overall dimensions	X	
• Inlets, outlets, and connections	X	
• Accessibility	X	
2. Sludge storage volume	X	
3. Watertightness	X	
4. Structural behaviour		X <sup>a</sup>
5. Treatment efficiency		X <sup>b</sup>
6. Durability		X <sup>c</sup>
a : the biggest size will normally be selected assuming this size represents the worst structural behaviour, b : the smallest size will normally be selected assuming this size represents the worst treatment efficiency c Specifically for steel plants TO BE DISCUSSED NEXT MEETING		

### 8.3 Factory production control

A factory production control system shall be established and documented. The factory production control system shall consist of procedures for the internal control of production to ensure that products placed on the market conform to this Standard.

### **8.3.1 Raw materials and components**

The specifications of incoming raw materials and components shall be verified.

### **8.3.2 Production process**

The relevant features of the plant and production process shall be defined giving the frequency of the inspection checks and tests, together with the criteria required for controlling and manufacturing process. The action to be taken when control values or criteria are not met shall be given.

Measuring equipment shall be calibrated and the procedure, frequency and criteria documented.

### **8.3.3 Finished product testing**

A sampling plan shall be prepared for the watertightness test of finished products and the results of tests shall be recorded and available. All test equipment shall be verified and the procedure, frequency and criteria documented.

### **8.3.4 Stock control**

The stock control of finished products, together with procedures for dealing with non-conforming products, shall be documented.

## **9 Installation instructions**

The Manufacturer shall supply installation instructions with each plant written in the language accepted in the country in which the plant is to be installed. These instructions shall contain comprehensive data for the installation of plants and all operating conditions including pipes connections, electrical connections and commissioning and start-up procedures. These instructions shall cover all installation conditions.

These instructions shall give the maximum backfill height, the bottom depth of the plant (H) and the maximum acceptable loading traffic loads.

NOTE The plant shall be sited to provide ready access for maintenance, particularly desludging equipment

## **10 Operation and maintenance instructions**

The Manufacturer shall provide with each plant clear and comprehensive operation and maintenance instructions written in the language accepted in the country in which the plant is to be installed.

NOTE It is strongly recommended that plant is maintained in accordance to the manufacturers instructions and that a Maintenance Contract is taken out with a competent Maintenance Contractor.

## BIBLIOGRAPHY

EN 872, *General requirements for components used in discharge pipes, drains and sewers for gravity systems.*

## Annex A (normative)

### Watertightness test

One of the watertightness test in table A1 shall be carried out on a complete plant whether factory manufactured or assembled from prefabricated components.

**Table A1 — Feasible tests**

Tests	Tank Material			
	Concrete	GRP	Polyethylene	Steel
Water test	X	X	X	X
Vacuum test		X	X	X
Pneumatic pressure test		X	X	X

#### A.1 Water test

##### A.1.1 Sample

The test is carried out on the plant.

##### A.1.2 Procedure

The plant shall be placed on a elevated open grid (5 cm minimum mesh width) and secured in place to enable inspection of the base of the plant.

The plant shall be filled with clean water to the top of the plant after sealing the connections. An interval of ½ hour shall elapse.

For plants with rigid behaviour, the volume of water required to refill the plant shall then be measured. For plants with flexible behaviour, they shall be inspected for leaks and the observation shall be recorded.

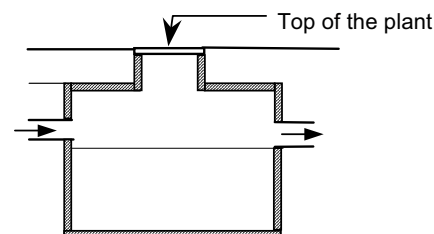

1 Top of the plant

**Figure 1 — Top of the plant**

##### A.1.3 Expression of results

For plants with rigid behaviour, at the end of the test period, the additional amount of clean water required to raise the water level up to the top of the plant shall be stated. This additional amount shall be expressed in litres and in litres per m<sup>2</sup> of the internal wet surface of the external walls.

## A.2 Air permeability vacuum test

### A.2.1 Sample

The test is carried out on an empty plant.

### A.2.2 Procedure

The plant shall be placed on a level surface and laterally supported. One of the three pressures given in table A.2 shall be chosen for the test.

The chosen vacuum pressure shall be gradually imposed on the plant and held for 3 mn to allow the plant to absorb the deformation.

After this, the variation of the pressure in the plant shall be measured during the related test period defined in Table A.2.

**Table A2 — Test parameter**

Gauge Test pressure	Test period
- 0,1 bar	60 s
- 0,2 bar	30 s
- 0,3 bar	15 s

### A.2.3 Expression of results

The value of the variation of the pressure shall be expressed in bars.

## A.3 Pneumatic pressure test

### A.3.1 Sample

The test is carried out on an empty plant.

### A.3.2 Procedure

**Table A.3 — Test parameter**

Gauge test pressure	Test period
+ 0,1 bar	60 s
+ 0,2 bar	30 s
+ 0,3 bar	15 s

The test shall be done according to one of the two followings methods :

**A.3.2.1.** The plant shall be placed on a level surface and laterally supported. One of the three pressures given in table A.2 shall be chosen for the test.

The chosen pneumatic pressure shall be gradually imposed on the plant and held for 3 mn to allow the plant to absorb the deformation.

After this, the variation of the pressure in the plant shall be measured during the related test period defined in table A.2.

**A.3.2.2.** The plant shall be placed on a level surface and laterally supported. The plant shall be subjected to an initial pneumatic pressure of 0,3 bar for at least 3 mn.

**A.3.3 Expression of results**

The value of the variation of the pressure shall be expressed in bars.

## **Annex B** **(normative)**

### **Treatment efficiency test procedure**

#### **B.1 Testing location**

The plant shall be tested at a laboratory or test centre.

#### **B.2 Plant selection and preliminary evaluation**

##### **B.2.1 General**

Before testing begins, the Manufacturer shall provide the laboratory with plant and process design specifications including a complete set of drawings and supporting calculations. Full information concerning the installation and operation and maintenance requirements of the plant shall also be provided.

The laboratory shall select the size of plant to be tested from the range submitted by the Manufacturer for approval. The smallest size will normally be selected to test for worst case conditions.

The Manufacturer shall provide the laboratory with information detailing the mechanical, electrical and structural safety of the plant installation to be tested.

The electrical specification of the installed plant shall conform to european standards.

##### **B.2.2 Installation and commissioning**

The plant shall be installed in a way that is representative of the normal conditions of use.

Test conditions, including environment and wastewater temperatures, and compliance with the manufacturer's manual shall be controlled and agreed upon by the laboratory. The plant shall be installed and commissioned in accordance with the manufacturer's instructions. The manufacturer shall install and commission all items of the plant prior to testing.

##### **B.2.3 Operation and maintenance procedures during testing**

The plant shall be operated in accordance with the Manufacturer's operating instructions. Routine maintenance shall be carried out in strict accordance with the Manufacturer's maintenance instructions. Sludge will only be removed from the plant when specified by the Manufacturer in his Operating & Maintenance Instructions. All maintenance work shall be recorded by the laboratory highlighting any maintenance work not specified in the O & M Manual.

During the test period no unauthorised access shall be permitted to the test site. Authorised access shall be supervised by the laboratory.

##### **B.2.4 Data to be monitored**

The following core parameters shall be monitored in all plants to be tested:

- a) biochemical oxygen demand (BOD)<sup>1)</sup> or chemical oxygen demand (COD),

---

1) BOD may be expressed in BOD<sub>5</sub> or BOD<sub>7</sub>

## **prEN 12566-3:2001 (E)**

- b) suspended solids (SS),
- c) temperature,
- d) power consumption,
- e) daily hydraulic flow.

The following parameters may also be measured if required:

- a) pH,
- b) Conductivity,
- c) KN or NH<sub>4</sub> – N,
- d) NO<sub>3</sub> – N,
- e) total phosphorus,
- f) hourly hydraulic flow,
- g) dissolved oxygen concentration (processes without gravity feed),
- h) sludge production.

### **B.3 Test procedure**

The laboratory will be required to test one plant from the range submitted for assessment by the Manufacturer in accordance with the testing procedure set out in this Standard.

#### **B.3.1 Time for establishment**

The laboratory shall monitor the time required to reach steady state conditions.

#### **B.3.2 Influent characteristics**

Where national regulations do not specify influent characteristics, it is recommended that the values tabulated below are used.

Raw domestic wastewater shall be used(it may be coarse screened and grit removed prior to use with the following quality):

- a) BOD<sub>5</sub> or BOD<sub>7</sub>(ATU) : 150 - 450 mg/l or COD: 300 - 900 mg/l,
- b) SS: 385 – 565 mg/l
- c) KN: 25 – 75 mg/l or NH<sub>4</sub> - N: 22,5 – 67,5 mg/l
- d) total phosphorus: 5 - 15 mg/l

### B.3.3 Daily flow pattern for testing

The daily flow used for testing purposes shall be measured by the laboratory. The daily flow pattern shall comply with Table B1 and Figure B1.

**Table B1 — Daily flow pattern**

Time of day	Percentage of daily flow
6 am to 9 am	30
9 am to 12 am	15
12 am to 6 pm	0
6 pm to 8 pm	40
8 pm to 11 pm	15
11 pm to 6 am	0

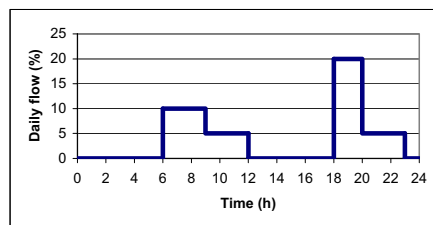

**Figure B1 — Daily flow pattern**

### B.3.4 Timetable for test procedure

Routine monitoring shall take place throughout the period of the test procedure. Steady-state performance shall be monitored for  $10 + X$  weeks to establish baseline performance before stress testing begins, where  $X$  is the time required to reach steady state conditions.

The test schedules listed in Table B.2 shall apply.

**Table B2 — Test schedules**

Nr	Characteristic	Time elapsed
1	No sampling Biomass establishment	X weeks <sup>a</sup>
2	Routine sampling Steady state performance	10 weeks
3	Power breakdown stress test	2 weeks
4	Routine sampling Steady state performance	6 weeks
5	Routine sampling 50 % nominal organic load with 50 % nominal hydraulic daily flow	2 weeks
6	Routine sampling 200 % nominal organic load with 200 % nominal hydraulic daily flow	2 weeks
7	Low occupation stress test	2 weeks
8	Routine sampling	6 weeks
9	Power breakdown stress test	2 weeks
10	Routine sampling	6 weeks
11	Low occupation stress test	2 weeks
12	Routine sampling	8 weeks

<sup>a</sup> X is the time required to reach steady state conditions.

The full test period is 48 + X weeks

After desludging a period of 1 day shall be allowed for recovery before the programme of tests and sampling is continued.

Power breakdown has a 24 hour duration.

**Table B3 — Definitions of overloads**

Nominal hydraulic flow	Nominal organic load	Extra load
≤ 600 l/day	≤ 240 BOD <sub>x</sub> g/d	200 %
601 to 1200 l/day	241 to 480 BOD <sub>x</sub> g/d	175 %
1201 to 1800 l/day	481 to 720 BOD <sub>x</sub> g/d	150 %
≥1801 l/day	> 720 BOD <sub>x</sub> g/d	125 %

The laboratory shall adjust the hydraulic daily flow in order to establish the extra load.

### B.3.5 Plant loading

The nominal organic and hydraulic loading for which the plant is designed, shall be delivered to the plant. Monitoring of wastewater composition and flow rates shall be carried out. If the conditions specified in B.3.2 are not met, the sampling data for that period shall not be used to determine treatment efficiency.

### B.3.6 Stress tests

#### B.3.6.1 Low occupation period

A low occupation period stress test shall be carried out twice a year, according to the conditions given in Table B.4.

**Table B4 — Low occupation period stress test**

Nominal hydraulic flow	Stress conditions
≤ 1200 l/day	No flow
> 1200 l/day	25 % Nominal hydraulic flow

**B.3.6.2 Washing machine test**

In addition to the daily flow pattern, a washing machine (75 – 100 L water) test shall be carried out twice a week on a full capacity (4-5 kg) boil wash with the manufacturer's recommended amount of domestic detergent. It shall commence at 10.00 a.m.

The washing machine stress tests shall not be executed in the low occupation period or during the 24 hour of peak flow.

**Table B5 — Washing machine discharge cycle**

Nominal hydraulic flow	Machines discharging
≤ 600 l/day	1
601 to 1200 l/day	2
1201 to 1800 l/day	3
> 1800 l/day	4

**B.3.6.3 Peakflow discharge test**

A peakflow discharge test simulating a bath water discharge shall be executed once a week according to the conditions given in Table B.6. In addition to the daily flow, a volume of 200 litres of test influent shall be discharged over a period of 3 mn, between the hours of 6 and 8 pm. .

**Table B.6 — Peakflow discharge**

Nominal hydraulic flow	Peakflow discharging
≤ 600 l/day	1
601 to 1200 l/day	2
1201 to 1800 l/day	3
> 1800 l/day	4

Peakflow discharge shall not be executed during low occupation periods or during 24 hour power breakdown.

**B.3.6.4 Power breakdown / Machine breakdown**

When applicable, a power breakdown test shall simulate loss of electric power/mechanical breakdown for 24 hours for the plant equipment but shall allow continued hydraulic flow.

**B.3.7 Sampling****B.3.7.1 Routine influent sampling**

The laboratory shall collect and analyse influent samples to determine compliance with the influent characteristics (see B.3.2). Samples shall be flow based composites over 24 hours taken at 15 day intervals.

**B.3.7.2 Routine effluent sampling**

Effluent samples shall be collected 4 weeks after the establishment period to determine plant performance. A 24 hours composite sample shall be taken every 15 days. The core parameters specified in B.2.4 shall be measured.

**B.3.7.3 Stress test sampling**

Stress test sampling shall be carried out on the effluent. The samples shall be 24 hour composites taken as specified in Table B.7.

Immediately the discharge is achieved, four samples shall be taken at 15 mn intervals. BOD or COD and Suspended Solids shall be measured.

When testing sequence batch reactors (SBR), the samples shall be taken during the next discharge cycling.

**Table B7 — Effluent sampling periods following stress**

Test condition	Sampling period following stress days
Low occupation	2nd and 5th day after test
Power breakdown	2nd and 5th day after test
Peakflow discharge	4 grab samples at 5 mn intervals immediately the discharge is achieved at 3 months intervals.

**B.4 Sample analysis**

The determinants specified in B.2.4 shall be analysed using the standard methods specified in the Standards listed below.

B.O.D.	ISO 5815
C.O.D.	ISO 6060
S.S.	EN 872
Ammonium nitrogen	ISO 5664
	or ISO 6778
	or ISO 7150-1
	or ISO 7150-2
	or EN ISO 11732
Kejdahl Nitrogen	EN ISO 11905-1
	or ENV 12260
Nitrate	ISO 7890-3
Phosphorus	EN 1189

Concentrations are determined for each load and each parameter. The minimum and maximum values, the average and the standing deviation (with the confidence interval of 95 %) shall be calculated on the result of a full test period and expressed in the test report.

**B.5 Test report**

The report shall contain, but not be limited to the data specified below:

- a) details of the plant tested including information regarding the nominal daily load;
- b) information on the conformity of the plant tested with the specification information provided prior to testing;
- c) the data obtained during testing;
- d) information on all maintenance and repairs carried out during the test period, including details of desludging frequency, quantity and the volume removed;

- e) information on the electrical energy absorbed during the test period;
- f) information on any problems, physical or environmental, occurring during the test period. Deviations from the manufacturers' maintenance instructions shall be reported in this section;
- g) information detailing any physical deterioration (eg: corrosion) of the plant that has occurred during the test period;
- h) information concerning deviations from the test procedure;
- i) the scaling rules used by the manufacturer to assess the same treatment efficiency and structural behaviour for all the products in the range.

## **B.6 Design changes**

Plants shall be retested if the treatment process and activity is negatively affected by e.g.: changes in design parameters, shape, change of media or equipment. Changes shall be evaluated by the laboratory.

## Annex C (normative)

### Calculation and test methods for structural behaviour

#### C.1 General

This annex gives the way to test the structural behaviour of plants which are installed into the ground (end use conditions a).

Structural behaviour of plants which are installed on the top of the ground (end use b) is validated by watertightness test and treatment efficiency test.

To determinate the structural behaviour of a plant, one or more method(s) described below and mentioned in Table C.1 shall be used.

**Table C1 — Methods for the determination of the structural behaviour**

Condition	Concrete	GRP	PE	Steel
Dry	C. 1.2.1 or C.1.2.3		C.2	
Wet	C.1.2.1. + C.1.2.2. or C.1.2.3	C.3.1 or C.5	C.4	C.3.2 or C.5
			-	C.5
				C.4
				C.5

#### C.2 Concrete plant

##### C.2.1 Crushing test methods

Table C.2 indicates the crushing test method to be performed according to the shape of the plant being tested.

**Table C2 — Crushing test methods**

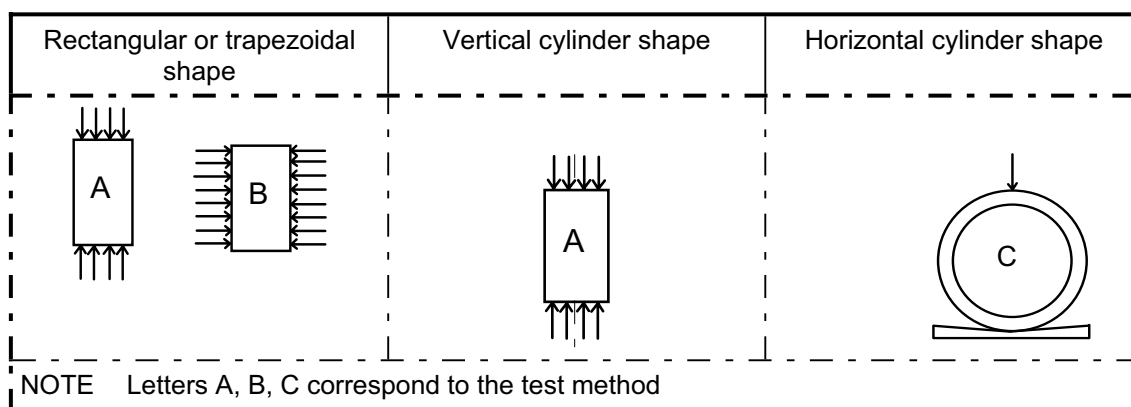

## C.2.2 Test procedures

### C.2.2.1 Type A test (vertical load)

#### C.2.2.1.1 Sample

The test shall be carried out on an empty plant equipped with its cover(s) without any extension and/or maintenance shaft.

#### C.2.2.1.2 Procedure

The plant shall be placed on a sand bed of granulometry 0-5 mm, water content approximately 7 % and thickness of  $(6 \pm 1)$  cm. This sand bed shall be levelled before the installation of the plant.

A similar sand bed shall be placed on the upper part in order to compensate for the thickness of the cover(s) and the geometry of the inner sides of the plant. The stress shall be equally distributed on the upper part of the plant using a loading plate. The stress shall be applied at a uniform rate and the maximum loading time shall not be less than 5mn. The tolerance on the load shall be  $\pm 3$  %. The stress shall be applied up to failure.

#### Key

- 1 loading plate
- 2 plywood plate
- 3 plywood retaining ring
- 4 stiff load beam
- 5 sand bed

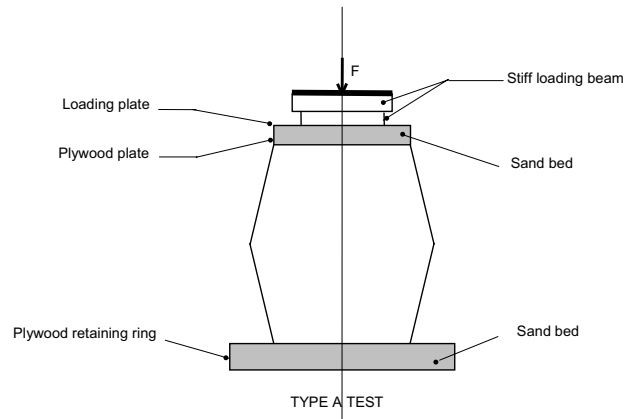

Figure C1 — Scheme of the principle of type A test

#### C.2.2.1.3 Expression of results

The load  $F$  corresponding to failure shall be noted and expressed in  $\text{kN/m}^2$  of the surface submitted to the load, excluding the cover.

### C.2.2.2 Type B test (horizontal load)

#### C.2.2.2.1 Sample

The test shall be carried out on an empty plant without its cover(s) and any extension and/or maintenance shaft.

#### C.2.2.2.2 Procedure

The plant shall be placed so that the upper surface (supporting the cover(s)) is in a vertical position.

The plant shall be placed on a sand bed as defined in C.2.2.1.2.

The stress shall be equally distributed on the plant using a loading plate or placed on a sand bed with the same characteristics. The sand bed shall be levelled to take into account the geometry of the sides of the plant (see scheme of principle in Figure C.1).

The stress shall be applied at a uniform rate and the maximum loading time shall not be less than 5 mn. The tolerance on the load shall be  $\pm 3$  %. The stress shall be applied up to failure.

Key

- 1 Loading plate
- 2 Plywood plate
- 3 Plywood retaining ring
- 4 Stiff loading beam
- 5 Sand bed

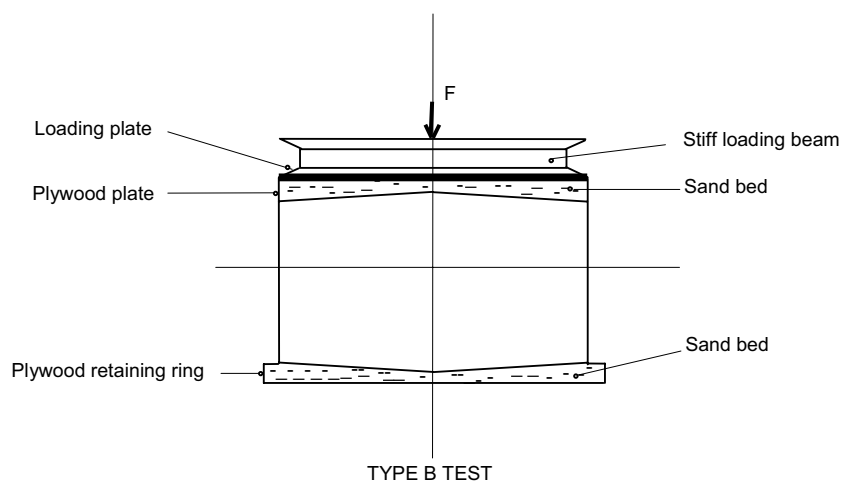

**Figure C2 — Scheme of principle of the type B test**

**C.2.2.2.3 Expression of results**

The load  $F$  corresponding to failure shall be noted and expressed in  $\text{kN/m}^2$  of the surface submitted to the load.

**C.2.2.3 Type C test (Vertical load)**

**C.2.2.3.1 Sample**

The test shall be carried out on an empty plant without its cover(s) and any extension and/or maintenance shaft.

**C.2.2.3.2 Procedure**

The plant shall be placed over its whole length on a "V" support forming a  $150^\circ$  angle and covered with a rubber strip of 50 mm wide and 10 to 20 mm thick.

The stress shall be applied at a uniform rate and the maximum loading time shall not be less than 5 mn. The tolerance on the load shall be  $\pm 3\%$ . The stress shall be applied up to failure.

## Key

- 1 rubber strip (10mm to 20mm thick)
- 2 rigid support (wood)

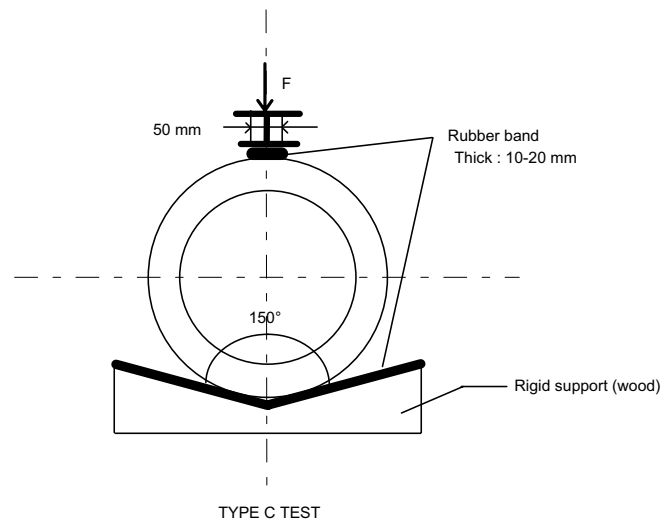

**Figure C3 — Scheme of principle of the type C test**

#### C.2.2.3.3 Expression of results

The load  $F$  corresponding to failure shall be noted and expressed in kN.

### C.3 Polyethylene plant

This test method is applicable for use in dry conditions only.

#### C.3.1 Vertical load test

##### C.3.1.1 Sample

The test shall be carried out on an empty plant equipped with its cover(s) without any extension and/or possible maintenance shafts.

##### C.3.1.2 Procedure

Testing shall be carried out at the temperature of  $25 \pm 5^\circ\text{C}$ .

The plant shall be placed in conditions representative of end use on a sand bed of granulometry 0-5 mm, water content less than 15 %. This sand bed shall be levelled to a thickness of  $6 \text{ cm} \pm 1 \text{ cm}$  before the installation of the tank.

A vertical stress shall be equally distributed on the upper part of the plant. A loading plate shall be adjusted to the centre of the upper part of the plant and shall be placed on a 1 cm thick soft plywood plate. If the upper part of the plant in contact with the loading plate is not plane (covers, raised points), level differences shall be compensated.

The stress shall be applied at a uniform rate and the maximum loading time shall not be less than 5 mn.

The tolerance on the load is  $\pm 3 \%$ .

The stress on the tank shall be increased to the collapse. Variation of  $h_t$  shall be noted, step by step. The maximum load  $F$  shall be noted and converted by dividing by the loaded section.

Key

- 1 distributed load
- 2 polyurethane foam
- 3 septic tank

$h_i$ : distance between the bottom of the plant and the axis of the inlet pipe

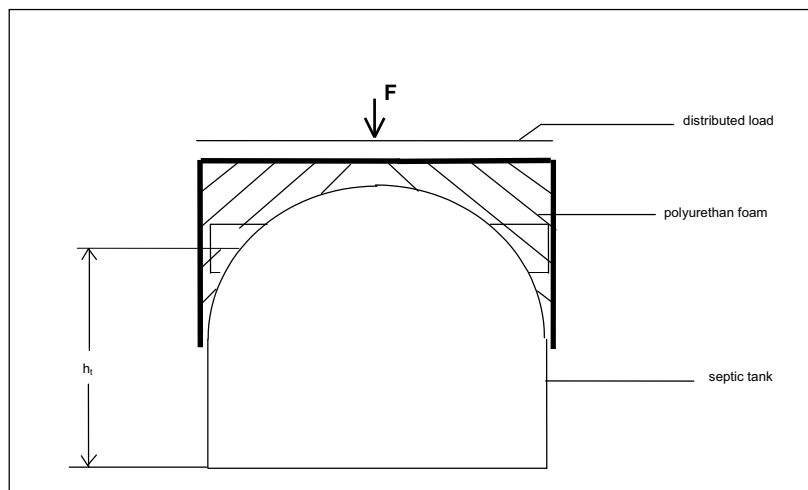

Figure C4 — Scheme of principle of PE plants test

**C.3.1.3 Expression of results**

The surface load corresponding to collapse shall be noted and expressed in  $\text{kN/m}^2$ .

**C.4 Determination of mechanical characteristics of test samples used for calculation**

**C.4.1 Concrete**

The preparation and the construction of the 150 mm x 300 mm cylindrical test samples shall be carried out in accordance with ISO 2736. The cylinders shall be in accordance with ISO 1920. The crushing resistance shall be determined according to ISO 4012.

**C.4.2 Glass Reinforced Plastic**

Specimen samples of laminate from the plant shall be prepared. The exposed edges shall be coated with the resin used in the manufacture of the plant. The samples shall be postcured in air at  $(50 \pm 2)^\circ\text{C}$  for a minimum of 72 hours. These specimen samples shall be immersed in water for 1000 hours at  $(50 \pm 2)^\circ\text{C}$ . Identical samples shall be stored as above in controlled conditions with air for 1000 hours at  $(20 \pm 2)^\circ\text{C}$ . Flexural modulus and strength of the samples shall be measured on all samples as determined by the method in EN 63.

**C.5 Vacuum test for Glass Reinforced Plastic or steel plant**

The plant shall be designed to withstand an external pressure  $P$ . The plant shall be tested for the designed external load in any conditions, using the following formula:

$$P = L \times f$$

where

- $P$  is the external pressure in kPa
- $L$  is the load in kN (greater of the vertical or horizontal load due to backfill + hydrostatic load, where applicable)
- $f$  is a factor ( $f \geq 1,5$ ) (factor to take into account of long term physical property of G.R.P. material or steel).

## C.6 Pit test

### C.6.1 Sample

The test shall be carried out on an empty plant equipped with pipe connections (inlet, outlet and interconnection pipes), its cover(s) and any extension and/or maintenance shaft(s).

The plant shall be installed in a watertight test excavation. The size of the testing excavation shall be calculated to avoid side effects. The plant shall be fixed on the base of the excavation, according to manufacturer's installation instructions.

The excavation shall be backfilled with preferably rounded gravel (3 to 8 mm).

To test in wet ground conditions, add water to the top of the plant, as defined in figure C5.

### C.6.2 Procedure

Step 1: Measure the initial internal dimensions of the plant.

Step 2: Place the plant in the test excavation.

Step 3: Backfill with gravel up to the level of pipe connections and simultaneously fill the plant with water up to the top, after sealing the inlet and outlet pipe connections. The volume of water shall be measured. After that, discharge the plant.

Step 4: Check the position of the inlet and outlet pipe connections.

Step 5: Complete the backfill up to the maximum permitted depth, including the pedestrian load (2,5 kN/m<sup>2</sup>) converted in uniformed backfill load and for a wet ground test, seal the inlet and outlet pipe connections and add water in the excavation to the level of the top of the plant.

Step 6: For a plant with a rigid behaviour, maintain the test conditions for 24 hours. For a plant with a flexible behaviour, maintain the test conditions for 3 weeks.

Step 7: Check the position of inlet and outlet pipe connections and the internal dimensions of the plant. Examine the inside of the plant to show the watertightness is maintained. If the plant is watertight, refill with the volume of water required to fill the plant before the test and measure any change in the capacity of the plant.

#### Key

- 1 water table level
- 2 backfill

Where

$$\alpha = \frac{\pi}{4} + \frac{\Phi}{2} = 63^\circ, \text{ with } \frac{\pi}{4} = 45^\circ \text{ and}$$

$\Phi$  = Angle of repose for gravel (3 to 8 mm) = 36°

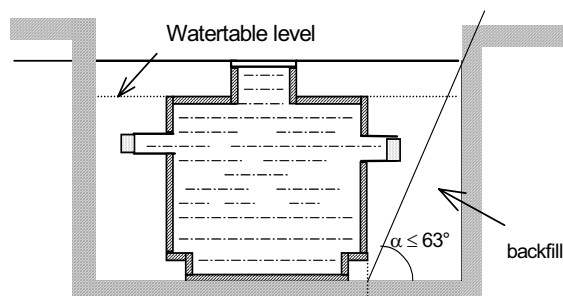

Figure C5 — Scheme of principle for the pit test

### **C.6.3 Expression of results**

The watertightness of the plant shall be confirmed as follows:

- The variation of internal dimensions of the plant shall be expressed in millimetres.
- The variation of the volume of the plant shall be expressed in litres.
- The movement of inlet, outlet and interconnecting pipe connections shall be expressed in millimetres.

## Annex ZA (informative)

### Clauses of this European standard addressing the provisions of the EU Construction Products Directive

#### ZA.1 Scope and relevant characteristics

This European standard has been prepared under Mandate M/118 " Waste water engineering products " given to CEN by the European Commission and the European Free Trade Association.

The clauses of this European standard shown in this Annex meet the requirements of the Mandate M/118 given under the EU Construction Products Directive (89/106/EEC).

Compliance with these clauses confers a presumption of fitness of the construction products covered by this annex for their intended uses indicated herein.

**WARNING:** Other requirements and other EU Directives, not affecting the fitness for intended use, may be applicable to the construction products falling within the scope of this standard.

**NOTE** In addition to any specific clauses relating to dangerous substances contained in this European Standard, there may be other requirements applicable to the products falling within its scope (e.g. transposed European legislation and national laws, regulations and administrative provisions). In order to meet the provisions of the EU Construction Products Directive, these requirements need also to be complied with, when and where they apply. An informative database of European and national provisions on dangerous substances is available at the Construction web site on EUROPA (CREATE, accessed through <http://europa.eu.int>).

This Annex has the same scope as Clause 1 of this standard with regard to the products covered. It establishes the conditions for the CE marking of small waste water treatment plants intended for the use indicated in Table ZA.1).

**Table ZA.1 Relevant characteristics**

Construction product: Small wastewater treatment systems up to 50 PT: prefabricated plants			
Intended use: Treatment of domestic wastewater for a population up to 50 PT			
Performance characteristic	Requirement clauses in this standard	Mandated levels and/or classes	Notes
Effectiveness of treatment	5.3 + Annex B	-	
Treatment capacity (nominal size)	4 + 6.1 + Annex B	-	The nominal size expressed in kg of BOD <sub>x</sub> per day and the hydraulic daily flow expressed in m <sup>3</sup> per day
Watertightness	5.4 + Annex A	-	Amount of leakage, expressed in l and/or l/m <sup>2</sup> or bars
Crushing resistance and maximum load deformation	5.5.5 + 6.2 + Annex C.1 + C.3 + C.4 + C.5	-	Calculation or test methods in Annex C
Durability	5.4. + 5.5.5 + 5.6	-	

**ZA.2 Procedure of attestation of conformity of plants**

**ZA.2.1 System of attestation of conformity**

The system of attestation of conformity for plants indicated in table ZA.2, in accordance with the decision of the Commission 95/467/EC as given in Annex 3 of the mandate M/118 "Wastewater engineering products", is shown in table ZA.2 for the indicated intended use.

**Table ZA.2 - Attestation of conformity system**

Product	Intended use	Level(s) or class(es)	Attestation of conformity system
Plants	To be used inside or outside buildings for faecal and organic effluents	—	3

The attestation of conformity of the plants in Table ZA.1 shall be based on the evaluation of conformity procedure indicated in Table ZA.3 resulting from the application of the clauses of this European standard indicated in table ZA.3.

**Table ZA.3 – Assignment of evaluation of conformity tasks**

Tasks		Content of the task	Evaluation of conformity clauses to apply
Tasks for the manufacturer	Factory production control (F.P.C.)	Parameters related to all characteristics of Table ZA.1	8.2.
	Initial type testing	All other characteristics of table ZA.1 other than those shown below	8.1.2.
Task for the notified body	Initial type testing	Checking the manufacturer calculation of the structural behaviour or crushing test or maximal load deformation test	8.1.2.
		Treatment efficiency test	
		Sludge storage volume test	
		Watertightness tests	
		Durability	

**ZA.2.2 Declaration of conformity**

When compliance with this Annex is achieved, the manufacturer or his agent established in the European Economic Area (EEA) shall prepare and retain a declaration of conformity, which authorises the affixing of the CE marking. This declaration shall include:

- name and address of the manufacturer, or his authorised representative established in the EEA, and place of production;
- description of the product (type, identification, use, ... ), and a copy of the information accompanying the CE marking;
- provisions to which the product conforms (e.g. Annex ZA of this EN);
- particular conditions applicable to the use of the product (e.g. provisions for use under certain conditions, etc);
- name and address (or identification number) of the approved body(ies);
- name of, and position held by, the person empowered to sign the declaration on behalf of the manufacturer or his authorised representative.

The above mentioned declaration shall be presented in the official language or languages of the Member State in which the product is to be used.

### ZA.3 CE Marking

The manufacturer or his authorised representative established within the EEA is responsible for the affixing of the CE marking. The CE marking symbol shall be in accordance with Directive 93/68/EEC and shall be shown on the accompanying commercial documents and in addition, on the products or the label fixed on the products. The following information and characteristics shall accompany the CE marking symbol (where relevant):

- name or identifying mark of the manufacturer
- the last two digits of the year of CE marking
- the number and the title of this standard (EN 12566-3)
- the product name and nominal size
- information on the relevant essential characteristics in Table ZA.1. Values to declare for each essential characteristic not included in the designation as:
  - structural behaviour: results of the calculation method, crushing test, vertical load test, vacuum test or pit test,
  - effectiveness of treatment: treatment efficiency test,
  - watertightness : water test, air permeability vacuum test or pneumatic pressure test,
  - material,
  - coating: material and thickness (where coating has been applied).

NOTE European legislation without national derogation need not be mentioned.

Table ZA. 4 gives an example of the information to be given on the commercial documents.

**Figure ZA.1 - Example CE marking information**

	<i>CE conformity marking, consisting of the "CE" symbol given in directive 93/68/EEC.</i>
<b>AnyCo Ltd</b> , P.O. Box 21, B – 1050  <b>99</b>	<i>Name or identifying mark and registered address of the producer  Last two digits of the year in which the marking was affixed</i>
<b>EN 12566-3</b> : Small wastewater treatment plants: prefabricated plants	<i>N° and title of European standard</i>
<b>Organic daily load</b> : xx kg of BOD <sub>5</sub> per day <b>Hydraulic daily load</b> : 1,2 m <sup>3</sup> /day  <b>Material:</b> <b>Watertightness</b> (water test) : passed <b>Crushing resistance</b> : yyy kN <b>Treatment efficiency</b> : COD : zzz g/ml.	<i>Description of product and Information on regulated characteristics</i>

**prEN 12566-3:2001 (E)**

In addition to any specific information relating to dangerous substances shown above, the product should also be accompanied, when and where required and in the appropriate form, by documentation listing any other legislation on dangerous substances for which compliance is claimed, together with any information required by that legislation.